



## OP-MP+813L1SD-20

### 10Gbps SFP+ Optical Transceiver, 20km Reach

#### Features

- ◆ Optical interface compliant to IEEE 802.3ae 10GBASE-LR
- ◆ Electrical interface compliant to SFF-8431 Hot Pluggable
- ◆ Duplex LC Connector
- ◆ 1310nm DFB transmitter, PIN photo-detector
- ◆ Operating case temperature: 0 to 70 °C
- ◆ Low power consumption
- ◆ Applicable for 20km SMF connection
- ◆ All-metal housing for superior EMI performance
- ◆ Advanced firmware allow customer system encryption information to be stored in transceiver
- ◆ Cost effective SFP+ solution, enables higher port densities and greater bandwidth. CE and FCC Compliant.

#### Applications

- ◆ 10GBASE-LR at 10.3125Gbps
- ◆ 10GBASE-LW at 9.953Gbps
- ◆ Other optical links

#### Product description

This 1310 nm DFB 10Gigabit SFP+ transceiver is designed to transmit and receive optical data over single mode optical fiber for link length 20km.

The SFP+ LR module electrical interface is compliant to SFI electrical specifications. The transmitter input and receiver output impedance is 100 Ohms differential. Data lines are internally AC coupled. The module provides differential termination and reduce differential to common mode conversion for quality signal termination and low EMI. SFI typically operates over 200 mm of improved FR4 material or up to about 150mm of standard FR4 with one connector.

In the transmit direction, the SFP+ transceiver module receives a 10.3125 Gb/s electrical signal (signaling rate) from the host board Asic/SerDes and converts the data to an optical signal via the Laser Driver that controls the Laser diode in the Transmitter Optical Sub-Assembly (TOSA). An open collector compatible Transmit Disable (Tx\_Dis) is provided. A logic "1," or no connection on this pin will

disable the laser from transmitting. A logic “0” on this pin provides normal operation. The transmitter has an internal automatic power control loop (APC) to ensure constant optical power output across supply voltage and temperature variations. An open collector compatible Transmit Fault (TFault) is provided. TX\_Fault is a module output contact that when high, indicates that the module transmitter has detected a fault condition related to laser operation or safety. The TX\_Fault output contact is an open drain/collector and shall be pulled up to the Vcc\_Host in the host with a resistor in the range 4.7-10 kΩ. TX\_Disable is a module input contact. When TX\_Disable is asserted high or left open, the SFP+ module transmitter output shall be turned off. This contact shall be pulled up to VccT with a 4.7 kΩ to 10 kΩ resistor

The receiver converts 10Gbit/s serial optical data into serial PECL/CML electrical data. An open collector compatible Loss of Signal is provided. Rx\_LOS when high indicates an optical signal level below that specified in the relevant standard. The Rx\_LOS contact is an open drain/collector output and shall be pulled up to Vcc\_Host in the host with a resistor in the range 4.7-10 kΩ, or with an active termination. Power supply filtering is recommended for both the transmitter and receiver. The Rx\_LOS signal is intended as a preliminary indication to the system in which the SFP+ is installed that the received signal strength is below the specified range. Such an indication typically points to non-installed cables, broken cables, or a disabled, failing or a powered off transmitter at the far end of the cable.

The 3rd functional capability of the SFP+ module is the 2 wire serial, I2C, interface. I2C is used for serial ID, digital diagnostics, and module control functions. The enhanced digital optical monitoring interface allows real time access to the device allowing monitor of received optical power, laser bias current, laser optical output power, etc.

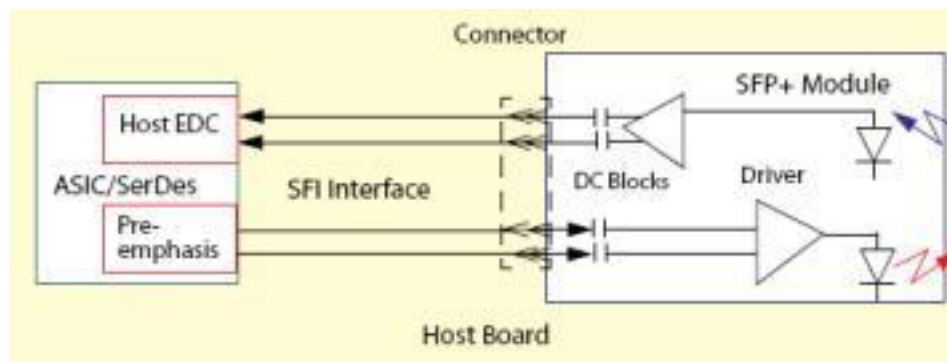

Figure 1: Interface to Host

### Pin definition

The SFP+ modules are hot-pluggable. Hot pluggable refers to plugging in or unplugging a module while the host board is powered. The SFP+ host connector is a 0.8 mm pitch 20 position right angle improved connector specified by SFF-8083, or stacked connector with equivalent with equivalent electrical performance. Host PCB contact assignment is shown in Figure 2 and contact definitions are given in Table 2. SFP+ module contacts mates with the host in the order of ground, power, followed by signal as illustrated by Figure 3 and the contact sequence order listed in Table 2.

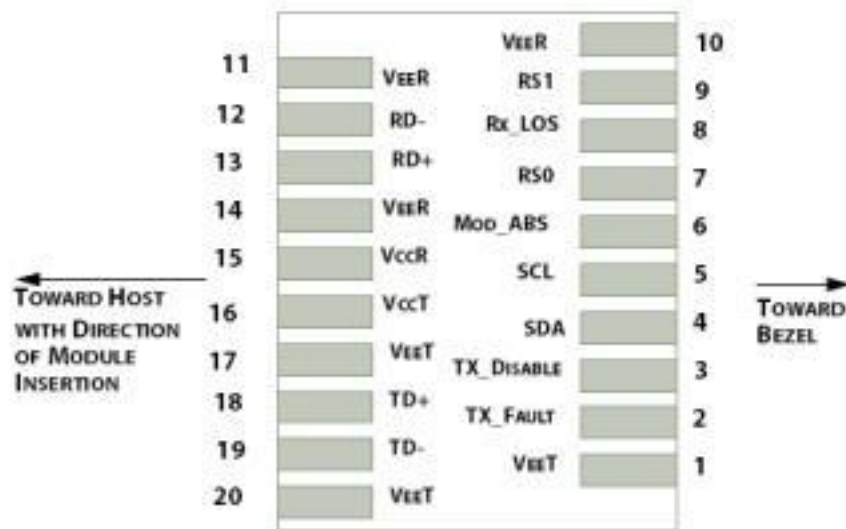

Figure 2: Interface to Host PCB

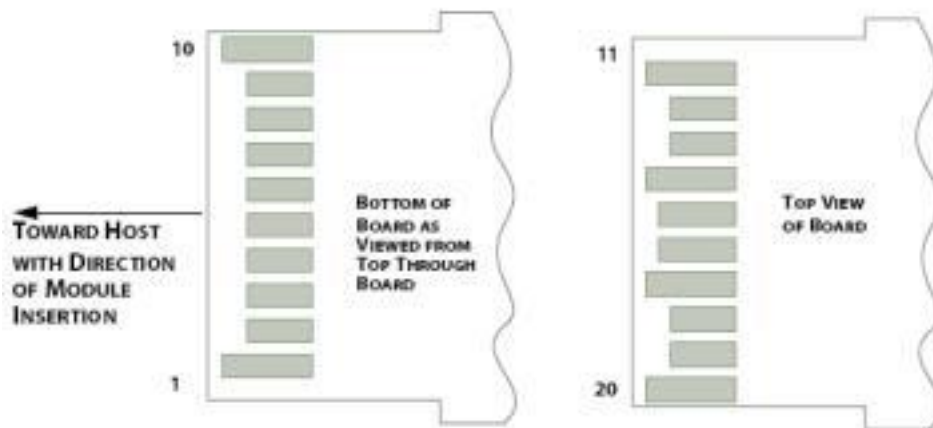

Figure 3: Module Contact Assignment



Communication Everywhere

<i>Contacts</i>	<i>logic</i>	<i>Symbol</i>	<i>Power Sequence Order</i>	<i>Name/Description</i>	<i>Note</i>
1		VeeT	1st	Module Transmitter Ground	1
2	LVTTL-O	TX_Fault	3rd	Module Transmitter Fault	2
3	LVTTL-I	TX_Disable	3rd	Transmitter Disable; Turns off transmitter laser output	3
4	LVTTL-I/O	SDA	3rd	2-wire Serial Interface Data Line (Same as MOD-DEF2 in the INF-8074i)	4
5	LVTTL-I/O	SCL	3rd	2-wire Serial Interface Clock (Same as MOD-DEF1 in the INF-8074i)	4
6		Mod_ABS	3rd	Module Absent, connected to VeeT or VeeR in the module	5
7	LVTTL-I	RS0	3rd	Rate Select 0, optionally controls SFP+ module receiver. When high input signaling rate > 4.25 GBd and when low input signaling rate ≤ 4.25 GBd.	6
8	LVTTL-O	Rx_LOS	3rd	Receiver Loss of Signal Indication (In FC designated as Rx_LOS and in Ethernet designated as <u>Signal Detect</u> )	2
9	LVTTL-I	RS1	3rd	Rate Select 1, optionally controls SFP+ transmitter. When high input signaling rate > 4.25 GBd and when low input signaling rate ≤ 4.25 GBd.	6
10		VeeR	1st	Module Receiver Ground	1
11		VeeR	1st	Module Receiver Ground	1
12	CML-O	RD-	3rd	Receiver Inverted Data Output	
13	CML-O	RD+	3rd	Receiver Non-Inverted Data Output	
14		VeeR	1st	Module Receiver Ground	1
15		VccR	2nd	Module Receiver 3.3 V Supply	
16		VccT	2nd	Module Transmitter 3.3 V Supply	
17		VeeT	1st	Module Transmitter Ground	1
18	CML-I	TD+	3rd	Transmitter Non-Inverted Data Input	
19	CML-I	TD-	3rd	Transmitter Inverted Data Input	
20		VeeT	1st	Module Transmitter Ground	1

Table 2: SFP+ Module PIN Definition



### Absolute maximum rating

These values represent the damage threshold of the module. Stress in excess of any of the individual Absolute Maximum Ratings can cause immediate catastrophic damage to the module even if all other parameters are within Recommended Operating Conditions.

Parameters	Symbol	Min.	Max.	Unit
Power Supply Voltage	Vcc	0	+3.6	V
Storage Temperature	Tc	-40	+85	C
Operating Case Temperature	Tc	0	+70	C
Relative Humidity	RH	5	95	%
RX Input Average Power	Pmax	-	0	dBm

Table 3: Absolute Maximum Rating

### Recommended operating environment

Recommended Operating Environment specifies parameters for which the electrical and optical characteristics hold unless otherwise noted.

Parameter	Symbol	Min.	Typical	Max	Unit
Power Supply Voltage	Vcc	3.135	3.300	3.465	V
Operating Case Temperature	Tc	0	25	70	C

Table 4: Recommended Operating Environment



Communication Everywhere

### Optical characteristics

The following optical characteristics are defined over the Recommended Operating Environment unless otherwise specified.

	Unit	Values
<b>Operating Reach</b>	<b>m</b>	<b>2-10K</b>
<b>Transmit</b>		
Center wavelength (range)	nm	1260 -1355
Side Mode Suppression Ratio (min)	dB	30
Launched power		
- maximum (Average)	dBm	+0.5
- minimum (Average)	dBm	-8.2 Notes1
- OMA	dBm	-5.2
- OMA-TDP (min)	dBm	-6.2
Transmitter and dispersion penalty (max)	dB	3.2
Average launch power of OFF transmitter (max)	dBm	-30
Extinction ratio (min)	dB	3.5 Notes2
RIN12 OMA (max)	dB/Hz	-128
Optical Return Loss Tolerance (min)	dB	12
<b>Receiver</b>		
Center wavelength (range)	nm	1260-1355
Receive overload (max) in average power <sup>1</sup>	dBm	0.5
Receive sensitivity (min) in average power <sup>1</sup>	dBm	-14.4 Notes3
Receiver sensitivity (max) in OMA (footnote 2)	dBm	-12.6 Notes3
Receiver Reflectance (max)	dB	-12
Stressed receiver sensitivity (max) in OMA <sup>2</sup>	dBm	-10.3
Vertical eye closure penalty (min) <sup>3</sup>	dB	2.2
Stressed eye jitter (min) <sup>2</sup>	Ulp-p	0.7
Receive electrical 3dB upper cutoff frequency (max)	GHz	12.3
Receiver power (damage, Max)	dBm	1.5
Notes:		
1. The optical power is launched into SMF		
2. Measured with a PRBS 2 <sup>31</sup> -1 test <a href="#">pattern@10.3125Gbps</a>		
3. Measured with a PRBS 2 <sup>31</sup> -1 test <a href="#">pattern@10.3125Gbps</a> BER ≤ 10 <sup>-12</sup>		

Table 5: Optical Characteristics

### Electrical characteristics

The following electrical characteristics are defined over the Recommended Operating Environment unless otherwise specified.



Parameter	Symbol	Min.	Typical	Max	Unit	Notes
Data Rate		-	10.3125	-	Gbps	
Power Consumption		-	1200	1500	mW	
<b>Transmitter</b>						
Single Ended Output Voltage Tolerance		-0.3	-	4.0	V	
C common mode voltage tolerance		15	-	-	mV	
Tx Input Diff Voltage	VI	90		350	mV	
Tx Fault	VoL	-0.3		0.4	V	At 0.7mA
Data Dependent Input Jitter	DDJ			0.10	UI	
Data Input Total Jitter	TJ			0.28	UI	
<b>Receiver</b>						
Single Ended Output Voltage Tolerance		-0.3	-	4.0	V	
Rx Output Diff Voltage	Vo	150		425	mV	
Rx Output Rise and Fall Time	Tr/Tf	30			ps	20% to 80%
Total Jitter	TJ			0.70	UI	
Deterministic Jitter	DJ			0.42	UI	

**Table 6: Electrical Characteristics**

### Control and status I/O timing characteristics

Timing characteristics of control and status I/O are included in Table 7, which is also defined in SFF-8431.

Parameter	Symbol	Min.	Max.	Unit	Conditions
TX_Disable assert time	t <sub>off</sub>		100	µs	rising edge of TX_Disable to fall of output signal below 10% of nominal
TX_Disable negate time	t <sub>on</sub>		2	ms	Falling edge of Tx_Disable to rise of output signal above 90% of nominal. This only applies in normal operation, not during start up or fault recovery.
Time to initialize 2-wire interface	t <sub>2w_start_up</sub>		300	ms	From power on or hot plug after the supply meeting <a href="#">Table 8</a> .
Time to initialize	t <sub>start_up</sub>		300	ms	From power supplies meeting <a href="#">Table 8</a> or hot plug or Tx disable negated during power up, or Tx_Fault recovery, until non-cooled power level I part (or non-cooled power level II part already enabled at power level II for Tx_Fault recovery) is fully operational.
Time to initialize cooled module	t <sub>start_up_cooled</sub>		90	s	From power supplies meeting <a href="#">Table 8</a> or hot plug, or Tx disable negated during power up or Tx_Fault recovery, until cooled power level I part (or cooled power level II part during fault recovery) is fully operational.
Time to Power Up to Level II	t <sub>power_level2</sub>		300	ms	From falling edge of stop bit enabling power level II until non-cooled module is fully operational
Time to Power Down from Level II	t <sub>power_down</sub>		300	ms	From falling edge of stop bit disabling power level II until module is within power level I requirements
TX_Fault assert	TX_Fault_on		1	ms	From occurrence of fault to assertion of TX_Fault
TX_Fault assert for cooled module	TX_Fault_on_cooled		50	ms	From occurrence of fault to assertion of TX_Fault
TX_Fault Reset	t <sub>reset</sub>	10		µs	Time TX_Disable must be held high to reset TX_Fault
RS0, RS1 rate select timing for FC	t <sub>RS0_FC</sub> , t <sub>RS1_FC</sub>		500	µs	From assertion till stable output
RS0, RS1 rate select timing non FC	t <sub>RS0</sub> , t <sub>RS1</sub>		10	ms	From assertion till stable output
Rx_LOS assert delay	t <sub>los_on</sub>		100	µs	From occurrence of loss of signal to assertion of Rx_LOS
Rx_LOS negate delay	t <sub>los_off</sub>		100	µs	From occurrence of presence of signal to negation of Rx_LOS

Table 7: Timing Characteristics

### Mechanical

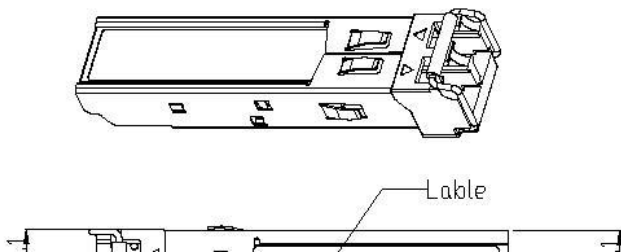





Communication Everywhere

Table 8: Key Mechanical Dimensions

**ESD**

This transceiver is specified as ESD threshold 1kV for high speed pins and 2kV for all other electrical input pins, tested per MIL-STD-883, Method 3015.4 /JESD22-A114-A (HBM). However, normal ESD precautions are still required during the handling of this module. This transceiver is shipped in ESD protective packaging. It should be removed from the packaging and handled only in an ESD protected environment.

**LASER SAFTY**

This is a Class 1 Laser Product according to IEC 60825-1:1993:+A1:1997+A2:2001. This product complies with 21 CFR 1040.10 and 1040.11 except for deviations pursuant to Laser Notice No. 50, dated (July 26, 2001)

**Ordering information**

Part Number	Product Description
OP-MP+813L1SD-20	1310nm, 10Gbps, 20km, 0°C ~ +70°C

E-mail: info@optostar.com.cn  
Web : www.optostar.com.cn